

Advanced Screed Control for Asphalt Pavers



- 3.5 in. Color Graphic LCD
- Compatible with Previous Generation System Five Configurations
- Waterproof and IP67 Rated
- Ruggedized Cable Design with Strong Strain Relief
- Operates Two Sides from One Control Box

P-32/P-32+ Advanced Screed Control for Asphalt Pavers

Topcon's Next Generation of Advanced Screed Control

Topcon continues its long tradition of innovation with the P-32/P-32+ asphalt paver systems. For decades, the Topcon System Five solution for paving has been the industry's premier non-contacting screed control system. Featuring durable and time-tested components, (Sonic Trackers, cross slope sensors, control boxes and the Trackerjack laser receiver), Topcon has introduced the successor of System Five with the introduction of the P-32/P-32+ asphalt paver system.

GC-35 Control Box

The 2D asphalt paver system features control boxes that are rugged and waterproof with an IP67 environmental rating. There is no need to worry about getting caught in a rainstorm, overspray from a water truck or putting wet control boxes into a carrying case.

The control boxes have a superior design, a faster processor and better on-screen options. The design with side-mounted cable connectors – versus bottom mounted – helps keep cables away from moving parts on the paver. The increased processor speed and improved on-screen options make the system run faster and more easily.

Sonic Averaging System

The Topcon Sonic Averaging System has been the paving industry's first choice as a non-contacting replacement to the conventional mechanical ski. The Sonic Averaging System is comprised of an aluminum beam with four Sonic Trackers which continuously measure the elevation over the surface, automatically averaging and adjusting the tow point cylinder. The Sonic Averaging System is convenient, maneuverable and produces a great finished surface.

GC-35 Paver System Control Box

Topcon has an exciting control box for its 2D asphalt paver system which can be sold on new pavers or as an upgrade to the System Five 9256 control boxes. The GC-35 also comes with a new mounting bracket, cables and a heavy duty double shelled carrying case.

With a 3.5 in. color graphics LCD, the display is easy to see day or night. You can view elevation and slope values for both sides of the screed from either side. Calibrating the system is much easier with on-screen menu choices and is faster than using the previous generation of control boxes.



GC-35 Paver System Control Box

- Waterproof and IP67 rated
- Backward compatible with System Five pavers
- Superior design with side mount connectors
- Faster processor and easy performance menu access
- Able to operate both sides from one control box



ST-3 Sonic Tracker

- Waterproof and IP67 rated
- Sideway offset indication on stringline
- Flat detection range on stringline
- Smoother and faster response
- Twice as fast detection speed



Dual Port Slope Sensor

- Exclusive anti-slosh ceramic technology
- Completely sealed internal electronics
- Rugged cast housing
- Insensitive to vibration
- Improved accuracy over extended temperature range



Trackerjack Laser Receiver

- 360° gapless receiving
- Motorized Trackerjack gets receiver on-grade quickly and "locks-on" to keep it there
- Bright grade indication LED's display continuous grade information
- Compatible with all Topcon lasers



PRIMARY FEATURES

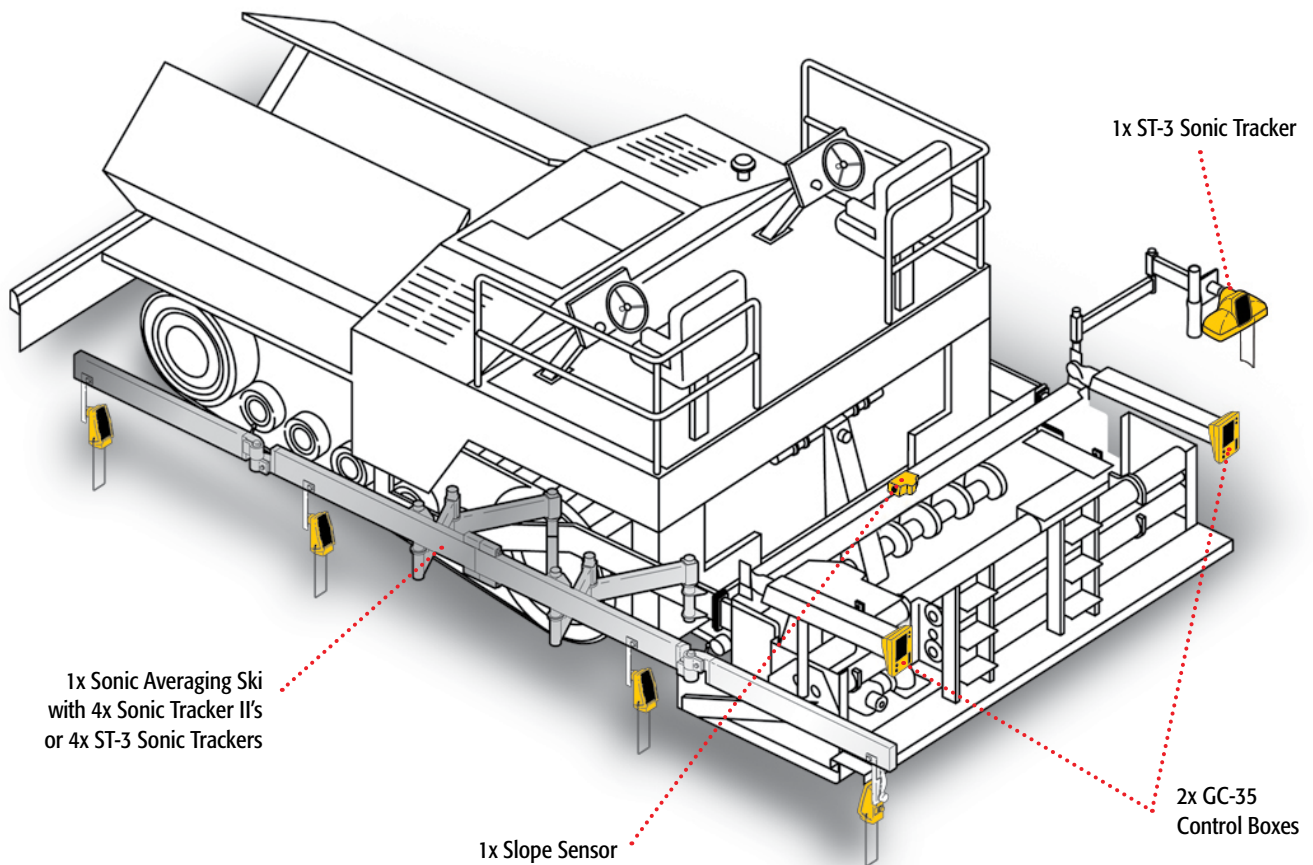

Smoothtrac®

Smoothtrac utilizes four Sonic Tracker sensors working in unison to provide superior averaging results while eliminating the cleaning and repair inherent in traditional skis. Smoothtrac adds additional electronic averaging to further smooth the ride. With Smoothtrac, you can back-up, turn around, even pave around curves without removing the ski. When not in use, it folds up and out of the way.



P-32+ KIT COMPONENTS

System Components

- 2x GC-35 Control Boxes
- 2x ST-3 Sonic Trackers
- Slope Sensor (optional)
- Laser Receiver (optional)
- SAS (optional)
- Manuals
- Carry Case and Cables



SPECIFICATIONS

GC-35 Control Box

Supply Voltage	10-30 VDC
Supply Current	10.5A max. operating current
Switch Output Power	10A valve output power 5A sensor output power 10A combined output power
Ports	USB RS-485 RS-232 CAN (2 ea.) External Auto Input
Display Panel	240x320 color TFT
Housing	Cast aluminum
Weight	2 lbs.
Operating Temperature	-40°C to 80°C

ST-3 Sonic Tracker

Target Range	14 in. to 36 in.
Ingress Protection	IP-67 IP-69K
Connectors	11 Pin Bayonet Shell Size 18
Operating Temperature	0°C to 80°C
Weight	3 lbs.
Compatibility	Sonic Tracker II Connector/Cable GC-35 for Stringline Mode and Surface Mode Other Control Boxes Surface Mode Only

Dual Port Slope Sensor

Range	± 0-20% Slope
Resolution (High)	± 0.00625% Slope
Operating Temperature	-20°C to 80°C
Weight	1.25 lbs.
Network	RS-485 proprietary port

For more specifications information:
topconpositioning.com/p-32

MILLIMETER GPS®

Millimeter GPS Paving

The next generation of asphalt paver control is fully upgradeable. Millimeter GPS - from the innovators in asphalt paver automation.

Imagine controlling your paver directly from digital site plans. As you pave, you're producing exact thickness at exact slope automatically. No following stringlines, curbs, or other surface references.

At the heart of Millimeter GPS® is Topcon LazerZone® technology. This revolutionary technology brings together the simplicity of a rotating laser, the accuracy of a robotic total station, and the flexibility and multiple user capabilities of GNSS, into one complete job site solution. Topcon combines this revolutionary new transmitter with the PZS-MC receiver, GX-60 control box and slope sensor to create a system that's changing the face of paver automation.



PZL-1A

The Positioning Zone Laser Transmitter operates similarly to a standard rotating laser, but transmits a unique LazerZone signal to provide a working range of 2000 ft. Instead of a traditional flat plane, the PZL-1A provides an incredible measuring area of 33 ft. in height. You can even link up to four laser transmitters for use on large sites to cover a distance of nearly 8,000 ft. with elevation changes of over 130 ft. No more taking time out to reposition your laser. With the PZL-1A, multiple machines can use the same transmitter, even at different elevations for continuous production.



PZS-MC

The PZS-MC (Positioning Zone Sensor - Machine Control) mounts to your paver in the same manner as traditional laser receivers. However, unlike traditional laser receivers, the PZS-MC knows its exact position within the 33 ft. vertical working range of the PZL-1A at every moment. With its integrated GNSS antenna, the PZS-MC continuously and accurately provides elevation and horizontal position information to the control box containing the digital site plans.

Knowing where the paver is located within the digital site plan, and knowing the grade required at that exact position, the control box sends correction signals to the screed to precisely maintain mat thickness and slope for that position on the site. Millimeter GPS is fast, continuously updating position and grade information so you work as fast as you want.

Your local Authorized Topcon dealer is:



7400 National Drive • Livermore • CA 94550
 (925) 245-8300

Specifications subject to change without notice. ©2014 Topcon Corporation
 All rights reserved. P/N: 7010-2130 Rev. B 5/14

The Bluetooth® word mark and logos are registered trademarks owned by Bluetooth SIG, Inc. and any use of such marks by Topcon is under license. Other trademarks and trade names are those of their respective owners.